

Build A Flare Canister Mount

Paul Esterle has been building or repairing watercraft, of all descriptions, for longer than he cares to admit, from hovercraft to power and sail boats. Paul specializes in boat improvement and repair projects utilizing wood, epoxy, and fiberglass. If you have any questions about your boat project, contact Paul at pesterle@preferred.com.

by Paul W. Esterle

One of the first projects I ever wrote about was building a mount for a standard orange flare canister. That mount was made from several pieces of mahogany and involved some cutting, filing and epoxying. It also required varnishing.

I decided to design a new mount while in the process of refitting our boat. This time I used polymer lumber, as produced by King Starboard (R) or Taco. Polymer lumber is great since it can be worked with common woodworking tools, doesn't absorb water and doesn't require finishing (or refinishing). This new flare canister mount requires a small piece of half-inch stock for the backboard and a couple of small three-quarter-inch thick stock for the cradles.

I started out by tracing the curve of the canister end on a piece of paper. From this I made templates for the cradles. I glued the templates to the three-quarter-inch polymer lumber stock with ordinary spray glue. After the glue dried, I cut them out with my saber saw. A new medium-toothed blade and a slow and careful cutting speed were the keys to getting a smooth cut.

I sanded the inside curves of the cradles with progressively finer grit sandpaper until a uniform satin finish, with no tool marks, appeared. I drilled a hole in each cradle for the bungee cord that holds the canister in place.

The backboard was a simple rectangle cut on the table saw. I spent some time rounding over all the exposed edges of the cradles and backboard with a round-over bit in my router. If you don't have a router, a small block plane or even sandpaper can be used to round the edges.

I fastened the cradles to the backboard with stainless steel flat head self-tapping screws. Be sure and drill pilot holes as well as countersink for the screws. I used a standard stainless steel hammock hook screwed

to the backboard to hold the bungee cord when looped over the canister.

The next to the last job was to install the bungee cord. I passed it through the hole in one of the cradles and knotted it on the outside of the mount. I then looped it over

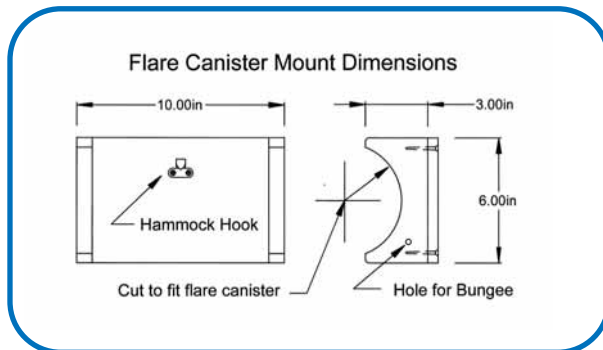

Dimensions of the flare canister



Overall view of the mount ready to install. Note the bungee cord and the hammock hook.

the flare canister, onto the hammock hook and out the hole in the other cradle. I adjusted the tension on the bungee until it was tight enough to hold the canister in place but still easy enough to pop off. After knotting the bungee cord, I put glue on the knots to keep them from coming undone.

The last job was to install the mount in place of the old mount. The location is just below the companionway hatch. I used stainless steel hardware including finishing washers and acorn nuts. Sitting in the cockpit, I can reach down into the cabin and pop out the flare canister single-handedly. The bungee cord holds the canister in place well enough that it could be mounted vertically as well as horizontally.

While the polymer lumber probably isn't cheaper than teak, I still like the clean design and the fact that I don't have to varnish and re-varnish the mount. Overall, this is a good project for a rainy weekend.



The finished mount installed below the companionway for quick access.

Season's Greetings



Wishing All Our Valued Advertisers and Readers

Happy & Healthy Holidays

from the entire Staff at Long Island Boating World